

平面図 S=1:100

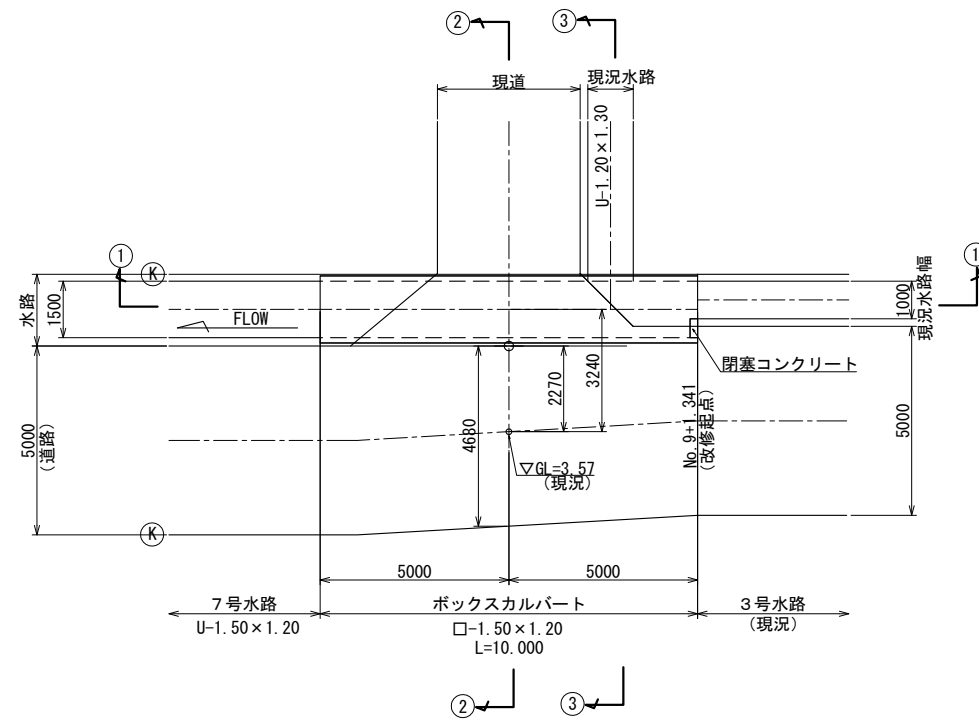

2-2断面図 S=1:50

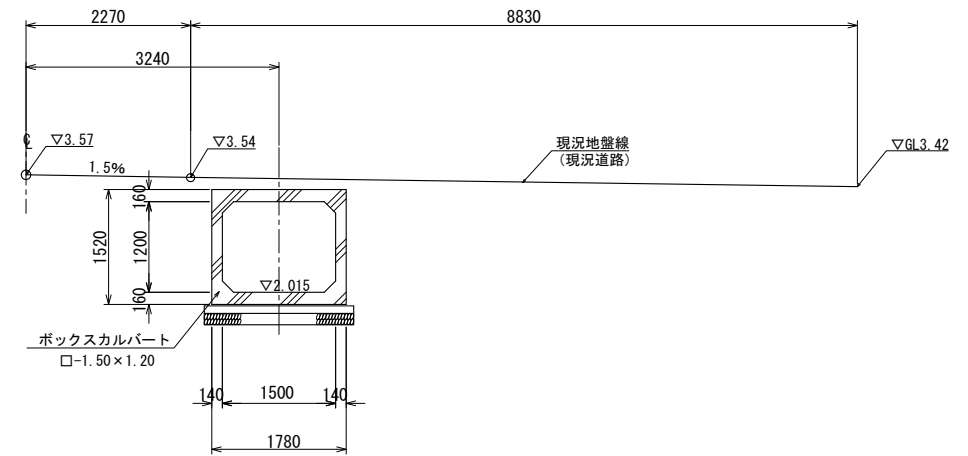

1-1断面図 S=1:50

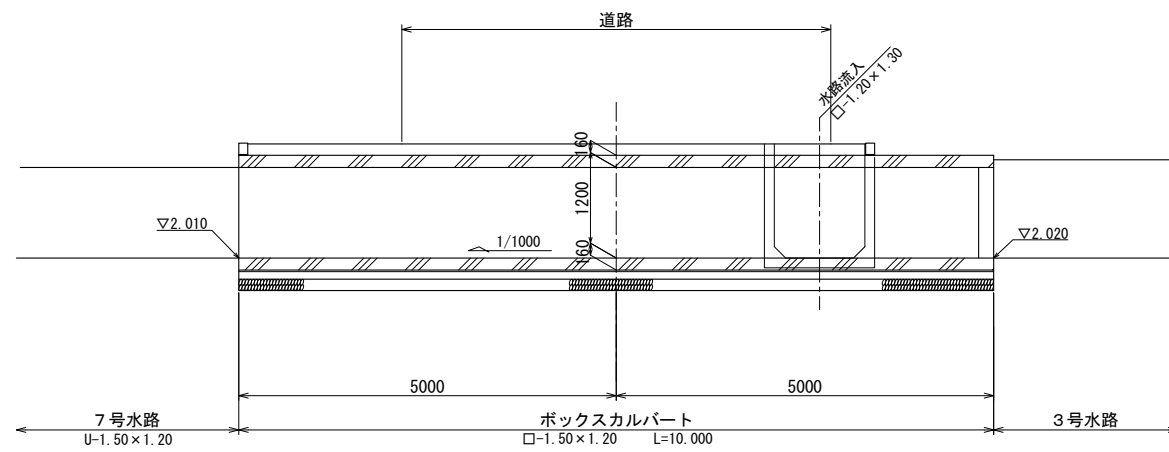

3-3断面図 S=1:50

